



Il fascino naturale della Pietra

*Catalogo
Cioffi Pietre di Trani*

An aerial photograph of a large stone yard. The yard is filled with numerous stacks of stone blocks, some wrapped in plastic. There are several buildings, including a large white one and a smaller one with a red roof. A road with a guardrail runs along the left side of the yard. The background shows a line of trees and a large white structure, possibly a greenhouse or a covered area.

Da oltre 30 anni sul mercato, **Cioffi Pietre di Trani** è divenuta ormai punto di riferimento nazionale per la vendita e lo smistamento della Pietra di Trani, nazionale ed estera in ogni sua forma. L'azienda può sempre assicurare, grazie ai 15000 mq. di esposizione, qualsiasi quantità di Pietre e Marmi allo stato naturale o lavorato. Ingegneri, architetti, geometri, costruttori e posatori, riescono a trovare presso la nostra azienda la risposta ad ogni loro particolare richiesta, oltre ad un valido servizio di consulenza in materia di montaggio, adattamento e posa in opera, ottenendo così risultati di massimo livello.



Francesco

COMMERCIALE
GESTIONE WEB
PREVENTIVI
ESTERO

☎ 3480846550

francesco@pietreditrani.it



Giangaetano

MAGAZZINO
ACQUISTI
CONSULENZA
ACCESSORI

☎ 3282543644

gaetano@pietreditrani.it



Serena

SEGRETERIA
STATO ORDINI
LOGISTICA
CONTABILITÀ

☎ 3456575735

info@pietreditrani.it



Cioffi Pietre di Trani s.r.l.
S. P. Trani/Andria, Km. 4
76125 Trani (BT) Italy

P.IVA: 06610880723 - Ufficio: 0883580098

PIETRE DI TRANI SCORZA

P. 10	SCORZA IN PIETRA DA RIVESTIMENTO	ART. 01
P. 11	SCORZA IN PIETRA DA PAVIMENTO	ART. 03
P. 12	LASTRONI IN PIETRA DA PAVIMENTO	ART. 04
P. 13	SCORZA ANTICATA DA RIVESTIMENTO	ART. 05
P. 14	SCORZA ANTICATA DA PAVIMENTO	ART. 05-06

PIETRE DI TRANI TRANCIATE

P. 18	LISTELLI TRANCIATI DA RIVESTIMENTO	ART. 07
P. 19	LISTELLI LATO TRANCIA	ART. 08
P. 20	LISTELLI TRANCIATI DA MURATURA	ART. 08
P. 21	PIASTRELLE TRANCIATE DA RIVESTIMENTO	ART. 09
P. 22	PIASTRELLE TRANCIATE DA PAVIMENTO	ART. 09-10
P. 23	ANGOLI IN PIETRA DI TRANI	ART. 07-11
P. 24	CUBETTI TRANCIATI	ART. 15

PIETRE DI TRANI ANTICATE

P. 28	LISTELLI TRANCIATI E ANTICATI	ART. 11-12
P. 29	LISTELLI ANTICATI AD ALTEZZA FISSA	ART. 27
P. 30	PIASTRELLE ANTICATE DA RIVESTIMENTO	ART. 13
P. 31	PIASTRELLE ANTICATE DA PAVIMENTO	ART. 14
P. 32	CUBETTI ANTICATI	ART. 16

RIVESTIMENTI IN PIETRA RUSTICA

P. 36	SCOPPATO IN PIETRA DI TRANI	ART. 17-18
P. 37	SCOPPATO BOLOGNINO IN PIETRA DI TRANI	ART. 18
P. 38	SCOPPATO ANTICATO IN PIETRA DI TRANI	ART. 19
P. 39	SCOPPATO ROSSO VERONA E GIALLO REALE	ART. 21
P. 40	ROCCIA NATURALE DA RIVESTIMENTO	ART. 150
P. 41	CIOTTOLI DI FIUME DA RIVESTIMENTO	ART. 151
P. 42	SCORZA RIFILATA IN PIETRA DI TRANI	ART. 22-23
P. 43	LISTELLI FRASTAGLIATI	ART. 23
P. 44	LISTELLINI IN PIETRA DI TRANI	ART. 27-28
P. 45	LISTELLINI IN TRAVERTINO	ART. 24-28

CIOTTOLI E PIETRE DA GIARDINO

P. 48	CIOTTOLI IN MARMO BIANCO DI CARRARA	ART. 29
P. 49	CIOTTOLI IN MARMO BIANCO ASSOLUTO	ART. 30
P. 50	CIOTTOLI IN PIETRA DI TRANI	ART. 36
P. 51	CIOTTOLI DI FIUME	ART. 37
P. 52	CIOTTOLI IN MARMO ROSSO VERONA	ART. 32
P. 53	CIOTTOLI IN MARMO VERDE ALPI	ART. 35
P. 54	CIOTTOLI IN MARMO GIALLO SIENA	ART. 33
P. 55	CIOTTOLI IN MARMO NERO EBANO	ART. 34
P. 56	CIOTTOLI IN MARMO ROSSO ROYAL	ART. 31
P. 57	GRANULATI IN MARMO COLORAZIONI VARIE	ART. 29-35
P. 58	LAPILLO VULCANICO	ART. 9-39
P. 59	ROCCE BUCATE GREZZE	ART. 46/A
P. 60	ROCCE BUCATE ANTICATE	ART. 47
P. 61	ROCCE BUCATE SABBIAE	ART. 47
P. 62	FONTANE IN PIETRA	ART. 48-49
P. 63	ARREDO GIARDINO IN PIETRA NATURALE	ART. 50-52
P. 64	TUFO ROMANO E TUFO PUGLIESE	ART. 48
P. 65	PIETRE DA GIARDINO DECORATIVE	ART. 76-77

PIETRE NATURALI NAZIONALI ED ESTERE

P. 68	PORFIDO DEL TRENTINO MOSAICO	ART. 53
P. 69	PORFIDO DEL TRENTINO MOSAICO GRANDE	ART. 53
P. 70	PORFIDO DEL TRENTINO CUBETTI	ART. 53
P. 71	PORFIDO DEL TRENTINO TRANCIATO	ART. 55
P. 72	QUARZITE BRASILIANA A MOSAICO	ART. 56
P. 73	PIETRA DI ROCCADASPIDE	ART. 57
P. 74	ARDESIA GRIGIA BEOLA	ART. 58
P. 75	ARDESIA VERDELLO E MARRONE	ART. 59
P. 76	PIETRA FOSSILE MOSAICO	ART. 60
P. 77	PIETRA DI LUSERNA MOSAICO	ART. 61
P. 78	PIETRA DI LUSERNA SQUADRATA	ART. 61
P. 79	SERIZZO FORMAZZA E ANTIGORIO	ART. 62
P. 80	ABACHINI IN ARDESIA	ART. 63
P. 81	PIETRA ALBA MOSAICO PIANO CAVA	ART. 64-66
P. 82	PIETRA ALBA MOSAICO ANTICATO	ART. 67-69
P. 83	PIETRA ALBA PIASTRELLE	ART. 70-73
P. 84	CARPARO LECCESE	ART. 78

PAVIMENTI E RIVESTIMENTI LAVORATI IN PIETRA E MARMO

P. 88	PALLADIANA IN PIETRA DI TRANI	ART. 79
P. 89	PALLADIANA IN TRAVERTINO	ART. 79
P. 90	PALLADIANA APULIA	ART. 82-84
P. 91	PALLADIANA MINI	ART. 85
P. 92	PIASTRELLE ANTICATE IN PIETRA E MARMO	ART. 86
P. 93	MARMETTE ANTICATE IN PIETRA DI TRANI	ART. 92
P. 94	MARMETTE SPAZZOLATE IN PIETRA DI TRANI	ART. 93
P. 95	MARMETTE BOCCIARDATE IN PIETRA DI TRANI	ART. 97
P. 96	MARMETTE BOCCIARDATE E ANTICATE IN PIETRA DI TRANI	ART. 97
P. 97	MARMETTE TRAVERTINO GOLD	ART. 93
P. 98	CHIANCHETTE ANTICATE IN PIETRA DI TRANI	ART. 94
P. 99	CHIANCHETTE ANTICATE IN TRAVERTINO	ART. 94
P. 100	COPERTINE IN PIETRA NATURALE E MARMO	ART. 87
P. 101	BATTISCOPIA LUCIDO IN PIETRA E MARMO	ART. 89-91
P. 102	PIETRA DI TRANI LAVORATA A MISURA	ART. 95
P. 103	MATTONI ANTICATI IN PIETRA DI TRANI	ART. 96
P. 104	PAVIMENTI E COPRIMURO IN TRAVERTINO ANTICATO	ART. 100

PIETRE DI TRANI PER CORDOLI E BASOLATI STRADALI

P. 108	BASOLE BOCCIARDATE SBECCATE IN PIETRA DI TRANI	ART. 101
P. 109	BASOLE PICCONATE ANTICATE IN PIETRA DI TRANI	ART. 102
P. 110	CORDOLI E ZANELLE IN PIETRA DI TRANI	ART. 103
P. 111	CORDOLI ANTICATI IN PIETRA DI TRANI	ART. 103

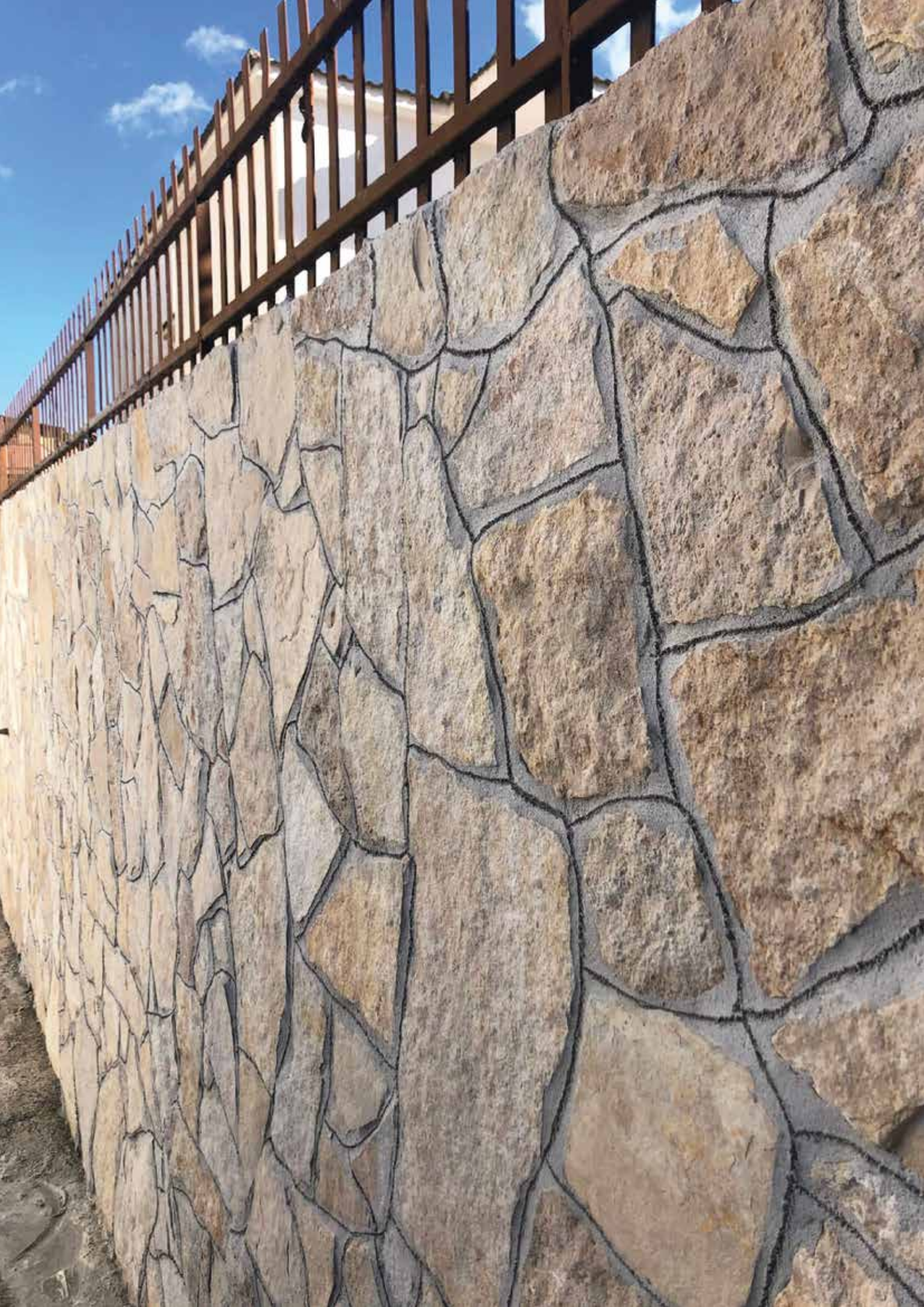

P *PIETRE DI TRANI SCORZA*

P. 10	SCORZA IN PIETRA DA RIVESTIMENTO	ART. 01
P. 11	SCORZA IN PIETRA DA PAVIMENTO	ART. 03
P. 12	LASTRONI IN PIETRA DA PAVIMENTO	ART. 04
P. 13	SCORZA ANTICATA DA RIVESTIMENTO	ART. 05
P. 14	SCORZA ANTICATA DA PAVIMENTO	ART. 05-06

Tipologia di Imballaggio

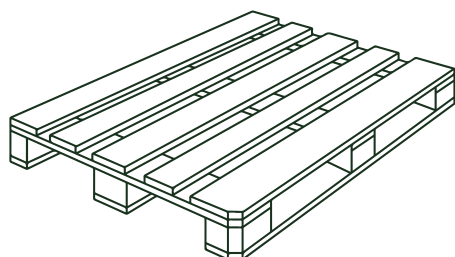

Caratteristiche



PIÙ SPAZIO EDIFICABILE

Vantaggi della pietra naturale
Volumetria ridotta



FACILE INSTALLAZIONE

Spessore contenuto
Semplicità di installazione



POSA IN OPERA NATURALE

Prodotto totalmente naturale



ECONOMICO

Costi contenuti

Pezzature Disponibili



Scorza in Pietra da Rivestimento



01 *spessore cm. 1-3 classica*
Pedana 900 kg. / 20-23 mq.
Colorazioni indicative:
bianco, giallo, rosso

02 *spessore cm. 1-2 o 1-3 retrosegata*
Pedana 700 kg. / 22-25 mq.
spessore cm. 1-3
Pedana 1100 kg. / 22-25 mq.
Colorazioni indicative:
bianco, giallo, rosso



Scorza in Pietra da Pavimento



03 *spessore cm. 3-4*
Pedana 1800 kg. / 25-28 mq.
Colorazioni indicative:
bianco, giallo, rosso

03 *spessore cm. 4-6*
Pedana 1800 kg. / 12-15 mq.
Colorazioni indicative:
bianco, giallo, rosso

Lastroni in Pietra da Pavimento

04



04 lastroni - spessore cm. 4-6
Pedana 1800 kg. / 12-15 mq.

04 lastroni - spessore cm. 6-9
Pedana 1800 kg. / 9-12 mq.

04 lastroni - spessore cm. 10-15
Pedana 1800 kg. / 6-9 mq.

Colorazioni indicative:
bianco, giallo, rosso



Scorza Anticata da Rivestimento



05
A *anticata spessore cm. 1-3
retrosegata*
Pedana 1100 kg. / 22-25 mq.
*ultrasottile spessore cm. 1-2
retrosegata*
Pedana 700 kg. / 22-25 mq.

05
B *semianticata spessore cm. 1-3
retrosegata*
Pedana 1100 kg. / 22-25 mq.

*ultrasottile semianticata spessore
cm. 1-2 retrosegata*
Pedana 700 kg. / 22-25 mq.

Colorazioni indicative: bianco, bianco
giallo

Scorza Anticata da Pavimento



05 anticata - spessore cm. 3-4
Pedana 1800 kg. / 22-25 mq.

06 lastroni - spessore cm. 4-6
Pedana 1800 kg. / 12-15 mq.

06 lastroni - spessore cm. 6-9
Pedana 1800 kg. / 9-12 mq.

Colorazioni indicative: bianco, bianco
giallo



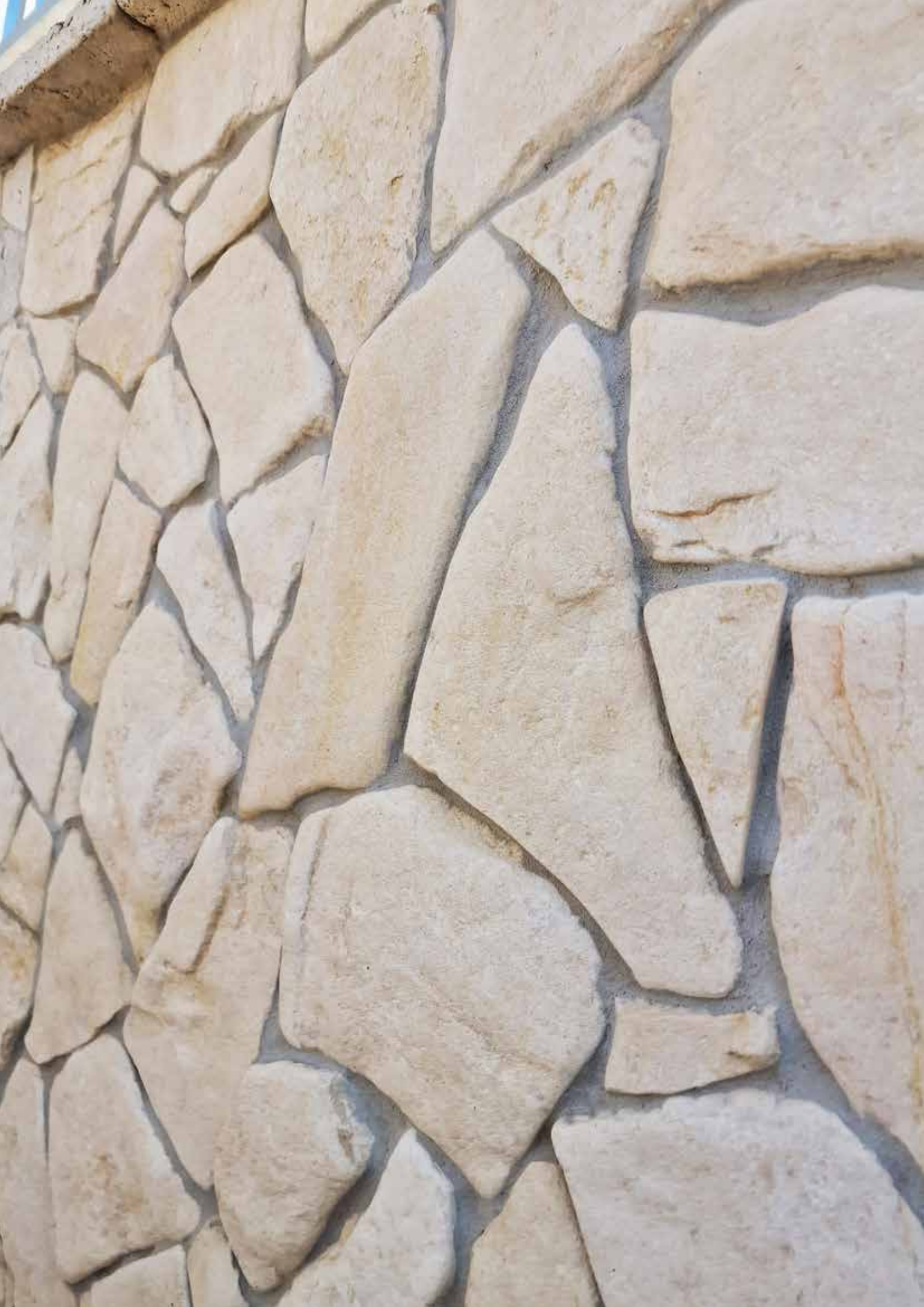

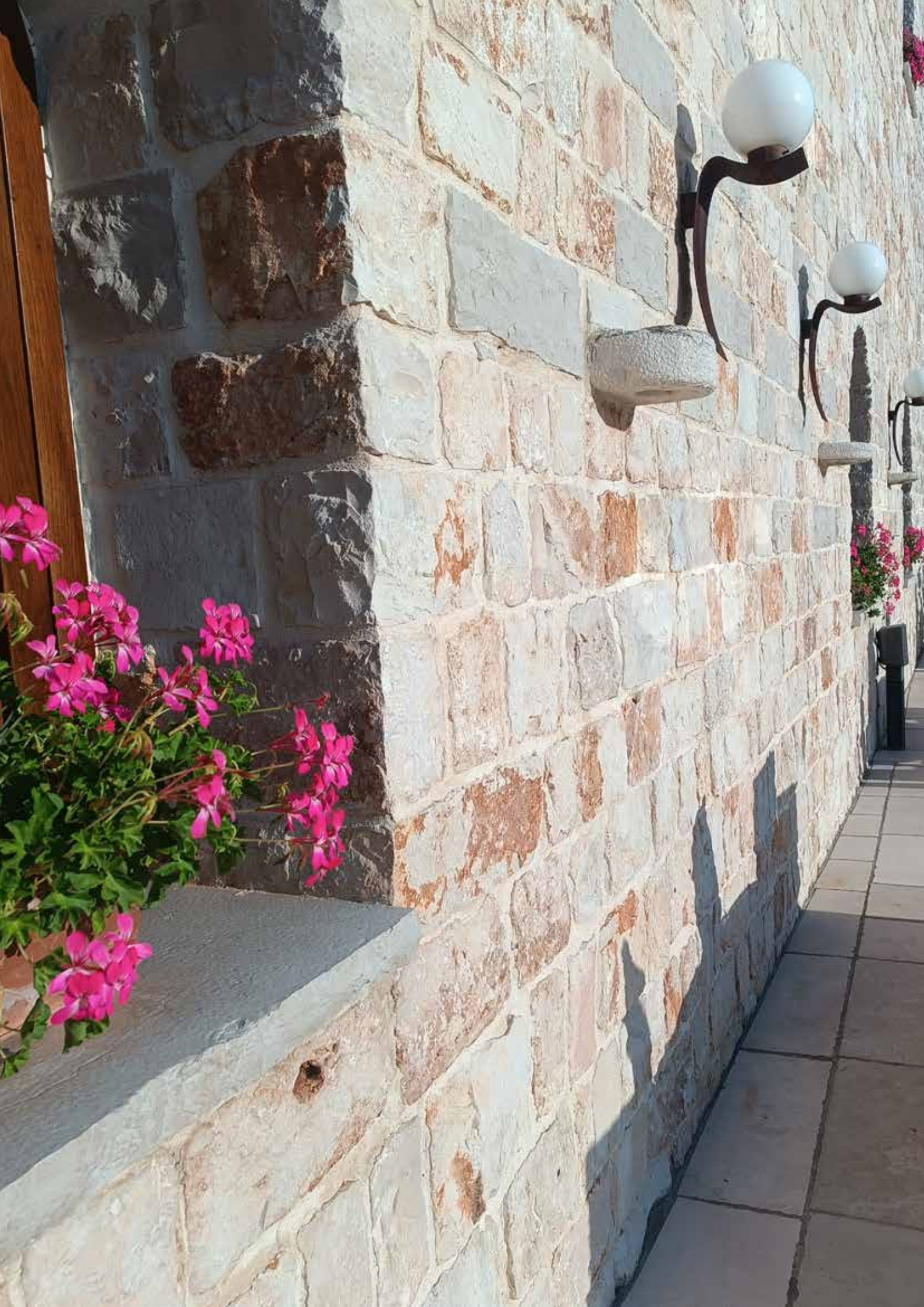

P *PIETRE DI TRANI TRANCIATE*

P. 18	LISTELLI TRANCIATI DA RIVESTIMENTO	ART. 07
P. 19	LISTELLI LATO TRANCIA	ART. 08
P. 20	LISTELLI TRANCIATI DA MURATURA	ART. 08
P. 21	PIASTRELLE TRANCIATE DA RIVESTIMENTO	ART. 09
P. 22	PIASTRELLE TRANCIATE DA PAVIMENTO	ART. 09-10
P. 23	ANGOLI IN PIETRA DI TRANI	ART. 07-11
P. 24	CUBETTI TRANCIATI	ART. 15

Tipologia di Imballaggio

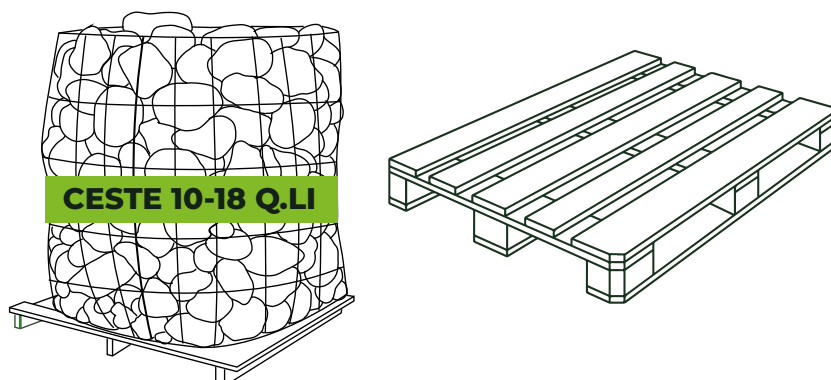

Caratteristiche



PIÙ SPAZIO EDIFICABILE

Vantaggi della pietra naturale
Volumetria ridotta



FACILE INSTALLAZIONE

Spessore contenuto
Semplicità di installazione



POSA IN OPERA NATURALE

Prodotto totalmente naturale



ECONOMICO

Costi contenuti

Pezzature Disponibili

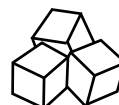
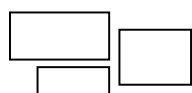

Listelli Tranciati da Rivestimento

07

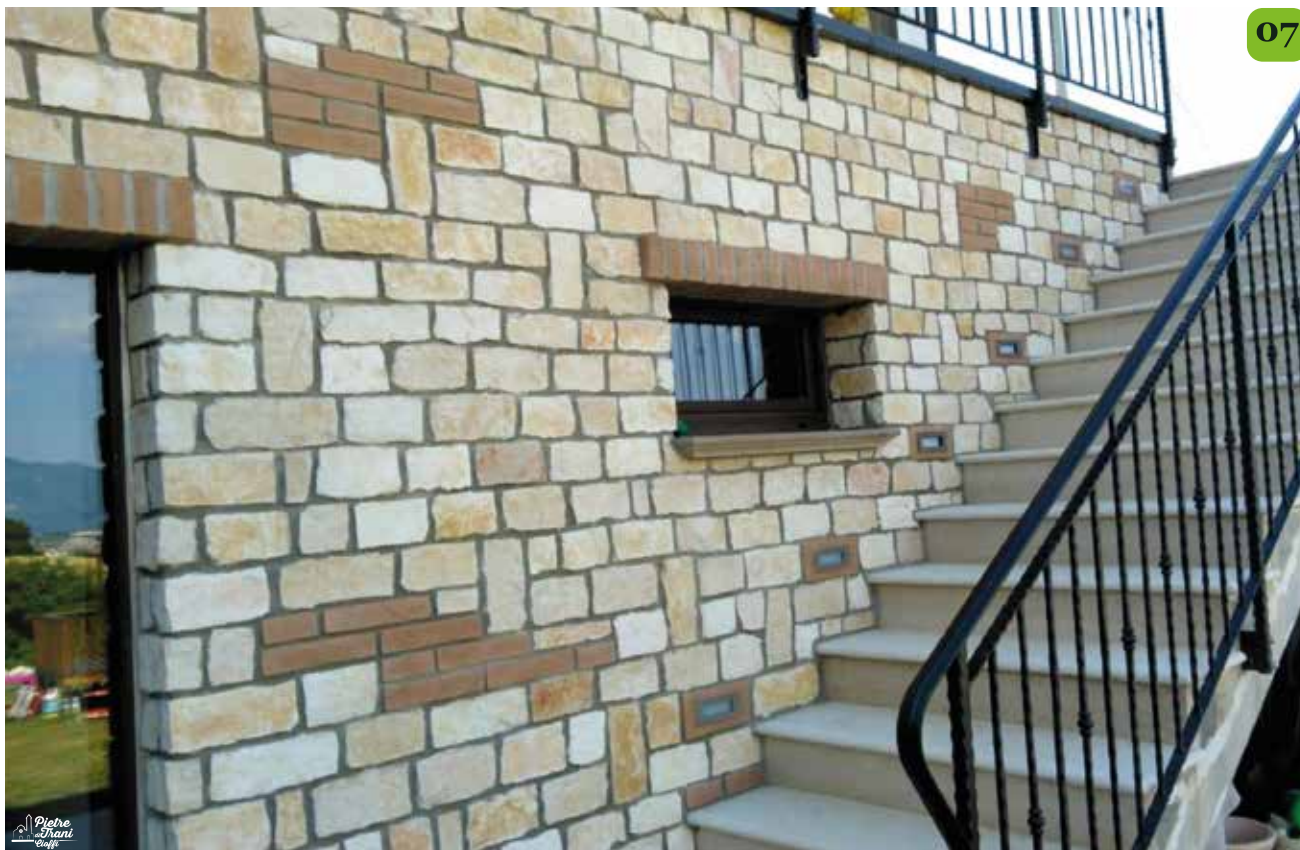

07

07 spessore cm. 1-3, cm. 8-10 a correre
Pedana 1100 kg. / 22-25 mq.
Colorazioni indicative: bianco, giallo

07 spessore cm. 1-3, cm. 5-7 a correre
Pedana 1100 kg. / 22-25 mq.
Colorazioni indicative: bianco, giallo

07 spessore cm. 2-4 , cm. 8-10 a correre
Pedana 1100 kg. / 22-25 mq.
Colorazioni indicative: bianco, giallo



07



07

Listelli Lato Trancia



08 h. cm. 5-15 / spessore cm. 2-4
Pedana 1300 kg. / 18-19 mq.
Colorazioni:
chiara, beige e multicolor



Listelli Tranciati da Muratura



08 *spessore cm. 4-6 / 4-6*
Pedana 1800 kg. / 15 mq. ca.
Colorazioni indicative: bianco e giallo

08 *spessore cm. 6-8 / 8-10*
Pedana 1800 kg. / 6-8 mq. ca.
Colorazioni indicative: bianco e giallo

08 *spessore cm. 8-10 / 8-10*
Pedana 1800 kg. / 6-8 mq. ca.
Colorazioni indicative: bianco e giallo

08 *spessore cm. 10-15 / 8-10*
Pedana 1800 kg. / 6-8 mq. ca.
Colorazioni indicative: bianco e giallo

08 *spessore cm. 15-20 / 8-10*
Pedana 1800 kg. / 6-8 mq. ca.
Colorazioni indicative: bianco e giallo



Piastrelle Tranciate da Rivestimento



09 *spessore cm. 1-3*
Pedana 1200 kg. / 22-25 mq.

09 *ultrasottile spessore cm. 1-2*
Pedana 700 kg. / 22-25 mq.

Colorazioni indicative:
bianco, giallo e rosso

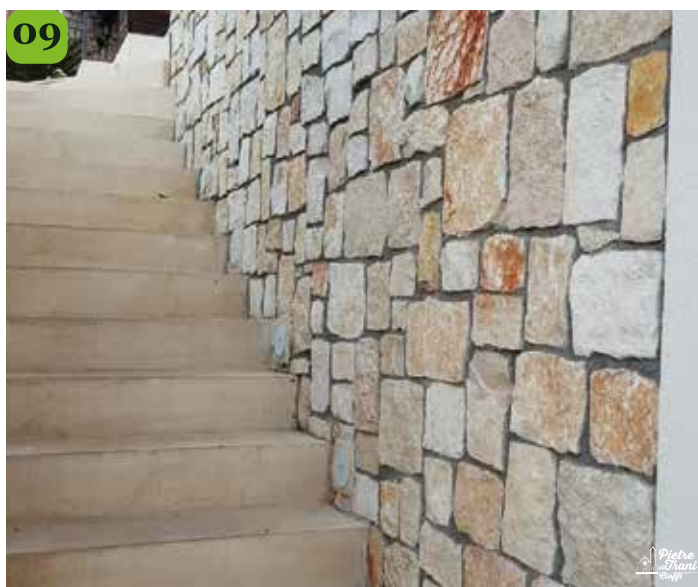

Piastrelle Tranciate da Pavimento



09 *spessore cm. 3-4*
Pedana 1800 kg. / 22-25 mq.

10 *spessore cm. 4-6*
Pedana 1800 kg. / 15-18 mq.

Colorazioni indicative:
bianco, giallo, rosso



Angoli in Pietra di Trani

07/D



11/C



07
D

Angoli Grezzi

h. cm. 10-40, spess. cm. 2/4

Colorazioni indicative: giallo e bianco

11
C

Angoli Anticati

h. cm. 10-40, spess. cm. 2/4

Colorazioni indicative: bianco



07/D



11/C

Cubetti Tranciati da Pavimento



15 *spessore cm. 4-6 / 6-8 / 8-10*
Piano calpestio cm. 4-6 / 6-8 / 8-10
Pedana 1800 kg. / 10-15 mq.
Colorazioni indicative:
bianco, giallo, rosso



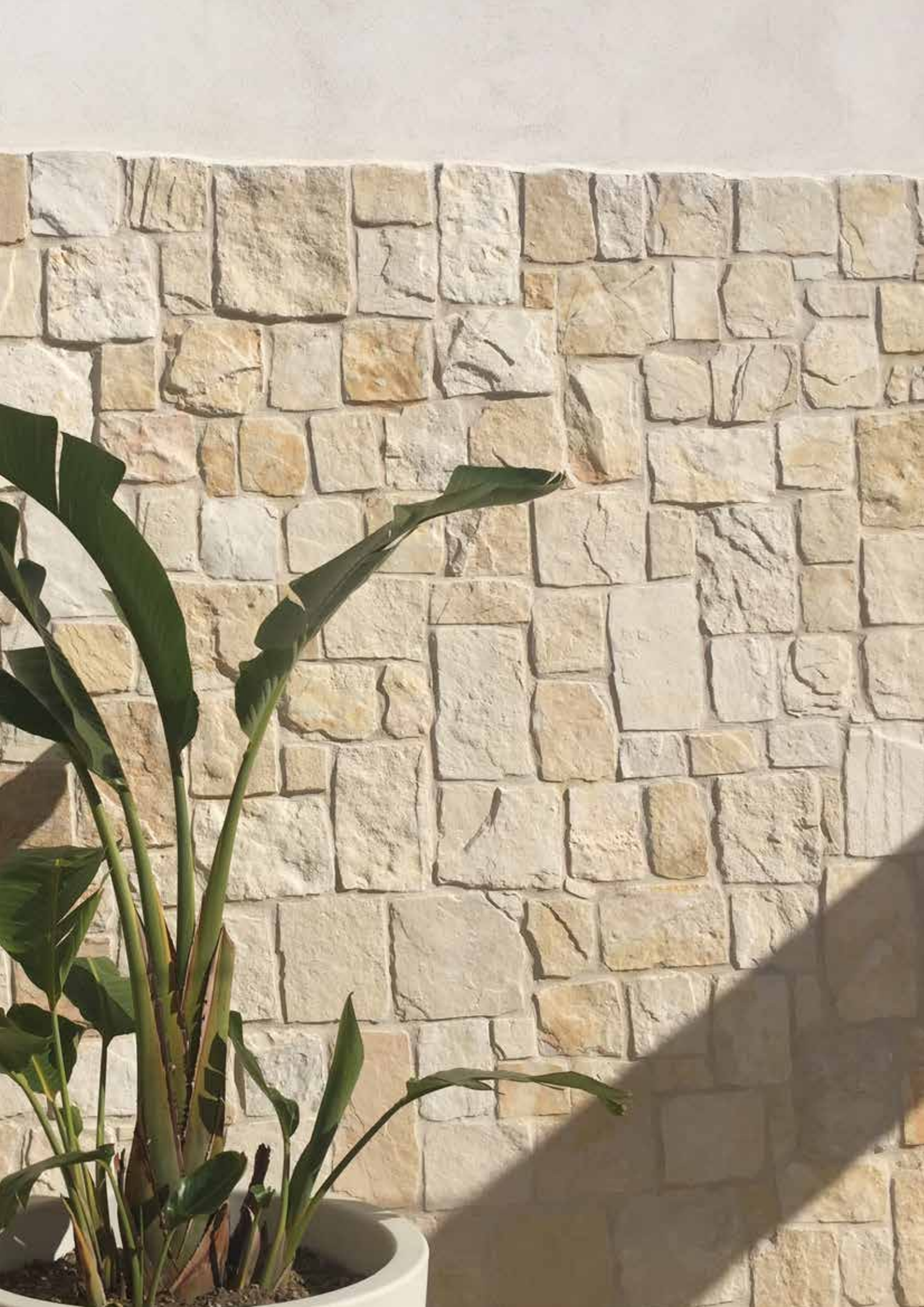



P *PIETRE DI TRANI ANTICATE*

P. 28	LISTELLI TRANCIATI E ANTICATI	ART. 11-12
P. 29	LISTELLI ANTICATI AD ALTEZZA FISSA	ART. 27
P. 30	PIASTRELLE ANTICATE DA RIVESTIMENTO	ART. 13
P. 31	PIASTRELLE ANTICATE DA PAVIMENTO	ART. 14
P. 32	CUBETTI ANTICATI	ART. 16

Tipologia di Imballaggio

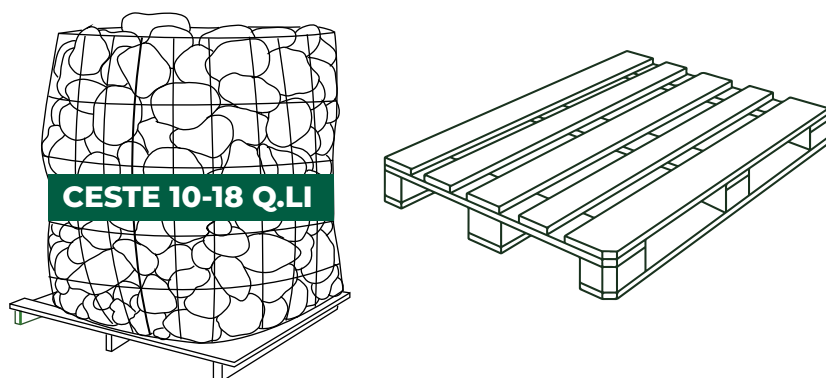

Caratteristiche



PIÙ SPAZIO EDIFICABILE

Vantaggi della pietra naturale
Volumetria ridotta



FACILE INSTALLAZIONE

Spessore contenuto
Semplicità di installazione



POSA IN OPERA NATURALE

Prodotto totalmente naturale



ECONOMICO

Costi contenuti

Pezzature Disponibili

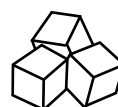
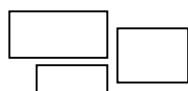

Listelli Tranciati e Anticati



11
Anticati sp. cm. 1-3
cm. 8-10 a correre
Pedana 1100 kg. / 22-25 mq.

11/B
Semianticati sp. cm. 1-3
cm. 8-10 a correre
Pedana 1100 kg. / 22-25 mq.

12
Anticati sp. cm. 4-6/6-8/8-10/10-15
da Muratura Pedana 1800 kg. / 6-17 mq.

Colorazioni indicative: bianco e giallo



Listelli Anticati ad Altezza Fissa

27



27 h. cm. 6-8-10 / spessore cm. 2-4
Pedana 1300 kg. / 18-19 mq.
Colorazioni indicative: chiaro stonalizzato



Piastrelle Anticate da Rivestimento

13 Anticate

sp. cm. 1-3

Pedana 1200 kg. / 22-25 mq.
Colorazioni indicative: bianco

13/B Semianticate

sp. cm. 1-3

Pedana 1200 kg. / 22-25 mq.
Colorazioni indicative: bianco
giallino



Piastrelle Anticate da Pavimento



13/C Anticate
spessore cm. 3-4
Pedana 1800 kg. / 22-25 mq.
Colorazioni indicative: bianco

13/D Semianticate
spessore cm. 3-4
Pedana 1800 kg. / 22-25 mq.
Colorazioni indicative:
bianco-giallino

14 Anticate
spessore cm. 4-6 / 6-8 / 8-10
Pedana 1800 kg. / 9-15 mq.
Colorazioni indicative: bianco



Cubetti Anticati



16 *spessore cm. 4-6 / 6-8 / 8-10*
Piano calpestio: cm. 4-6 / 6-8 / 8-10
Pedana 1800 kg. / 10-18 mq.
Colorazioni indicative: bianco anticato







RIVESTIMENTI IN PIETRA RUSTICA

P. 36	SCOPPATO IN PIETRA DI TRANI	ART. 17-18
P. 37	SCOPPATO BOLOGNINO IN PIETRA DI TRANI	ART. 18
P. 38	SCOPPATO ANTICATO IN PIETRA DI TRANI	ART. 19
P. 39	SCOPPATO ROSSO VERONA E GIALLO REALE	ART. 21
P. 40	ROCCIA NATURALE DA RIVESTIMENTO	ART. 150
P. 41	CIOTTOLI DI FIUME DA RIVESTIMENTO	ART. 151
P. 42	SCORZA RIFILATA IN PIETRA DI TRANI	ART. 22-23
P. 43	LISTELLI FRASTAGLIATI	ART. 23
P. 44	LISTELLINI IN PIETRA DI TRANI	ART. 27-28
P. 45	LISTELLINI IN TRAVERTINO	ART. 24-28

Tipologia di Imballaggio

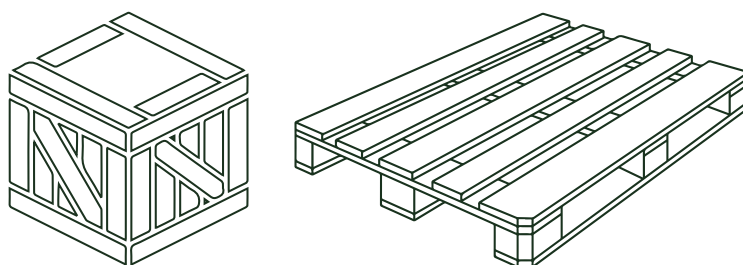

Caratteristiche



PIÙ SPAZIO EDIFICABILE

Vantaggi della pietra naturale
Volumetria ridotta



FACILE INSTALLAZIONE

Spessore contenuto
Semplicità di installazione



POSA IN OPERA NATURALE

Prodotto totalmente naturale



ECONOMICO

Costi contenuti

Pezzature Disponibili

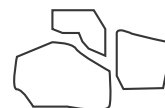
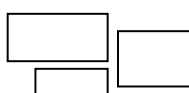

Scoppato in Pietra di Trani



17



17



17

17 classico sez. cm. 10x30x2-3, 15x30x2-3
Pedana 1500 kg. / 22-25 mq.
Colorazioni indicative: beige Trani

18 rombo sez. cm. 15x30x2-3
Pedana 1100 kg. / 22-25 mq.
Colorazioni indicative: beige Trani



17



18

Scoppato Bolognino in Pietra di Trani



18 *bolognino sez. cm. 15x30x3, 20x30x3*
Pedana 1500 kg. / 22-25 mq.
Colorazioni indicative: beige Trani



Scoppato Anticato in Pietra di Trani



19

19 sez. cm. 10x30x2-3 / 15x30x2-3
Pedana 1500 kg. / 22-25 mq.
Colorazioni indicative: bianco anticato



cm. 10X30X2



cm. 15X30X2

Scoppato Rosso Verona e Giallo Reale



21
A

Rosso Verona
sez. cm. 30x10x2
Pedana 1500 kg. / 25 mq. ca.



21
B

Giallo Reale
sez. cm. 30x10x2
Pedana 1500 kg. / 25 mq. ca.



Roccia Naturale da Rivestimento



149



149



150

149 *Grezza Segata spess. cm. 2-4*

150 *Anticata Segata spess. cm. 2-4*

Pedana 1800 kg. / 25 mq. ca.



150

Ciottoli di Fiume da Rivestimento



151 Ciottoli Segati Grigi spess. cm. 1-4 - Pedana 1800 kg. / 25 mq. ca.



Scorza Rifilata in Pietra di Trani

- 22** *spessore cm. 2-7*
Pedana 1500 kg. / 10-15 mq.
Colorazioni indicative:
multicolor



Listelli Frastagliati

23



23 altezza cm. 4-10 / spessore cm. 2-7 / lunghezze cm. 10-40
Pedana 1200 kg. ca. / 10-12 mq. ca.
Colorazioni indicative: multicolor

23



Listellini in Pietra di Trani



25 listelli anticati
sez. cm. 5 a correre, sp. cm. 1
Pedana 1000 kg. / 30 mq.

26 listelli scoppati
sez. cm. 3-4-5 a correre,
sp. cm. 2-3
Pedana 1000 kg. / 30 mq.

25 A spazzolati tipo "capricciosi"
sez. cm. 8 a correre, spess. cm. 1
Pedana 900 kg. / 30 mq.



Listellini in Travertino



24 **Travertino Chiaro Anticato**
sez. cm. 5 a correre, sp. cm. 1
Pedana 750 kg. / 30 mq.

24
A **Travertino Noce Anticato**
sez. cm. 5 a correre, sp. cm. 1
Pedana 750 kg. / 30 mq.

28
A **Travertino Mix Scoppato**
sez. cm. 4 a correre, sp. cm. 3-4
Pedana 750 kg. / 10 mq. ca.

Colorazioni: chiaro o noce





C IOTTOLI E PIETRE DA GIARDINO

P. 48	CIOTTOLI IN MARMO BIANCO DI CARRARA	ART. 29
P. 49	CIOTTOLI IN MARMO BIANCO ASSOLUTO	ART. 30
P. 50	CIOTTOLI IN PIETRA DI TRANI	ART. 36
P. 51	CIOTTOLI DI FIUME	ART. 37
P. 52	CIOTTOLI IN MARMO ROSSO VERONA	ART. 32
P. 53	CIOTTOLI IN MARMO VERDE ALPI	ART. 35
P. 54	CIOTTOLI IN MARMO GIALLO SIENA	ART. 33
P. 55	CIOTTOLI IN MARMO NERO EBANO	ART. 34
P. 56	CIOTTOLI IN MARMO ROSSO ROYAL	ART. 31
P. 57	GRANULATI IN MARMO COLORAZIONI VARIE	ART. 29-35
P. 58	LAPILLO VULCANICO	ART. 9-39
P. 59	ROCCE BUCATE GREZZE	ART. 46/A
P. 60	ROCCE BUCATE ANTICATE	ART. 47
P. 61	ROCCE BUCATE SABBIAATE	ART. 47
P. 62	FONTANE IN PIETRA	ART. 48-49
P. 63	ARREDO GIARDINO IN PIETRA NATURALE	ART. 50-52
P. 64	TUFO ROMANO E TUFO PUGLIESE	ART. 48
P. 65	PIETRE DA GIARDINO DECORATIVE	ART. 76-77

Tipologia di Imballaggio



Caratteristiche



PIÙ SPAZIO EDIFICABILE

Vantaggi della pietra naturale
Volumetria ridotta



FACILE INSTALLAZIONE

Spessore contenuto
Semplicità di installazione



POSA IN OPERA NATURALE

Prodotto totalmente naturale



ECONOMICO

Costi contenuti

Ciottoli in Marmo Bianco di Carrara

29



mm
07
15

mm
15
25

mm
25
40

mm
40
60

mm
60
100

mm
80
150

mm
150
250

Ciottoli in Marmo Bianco Assoluto

30



Ciottoli in Pietra di Trani



36



36



mm
10
30



mm
60
80



mm
25
40



mm
80
120



mm
40
60

Ciottoli di Fiume

37

Pietre
Franti
S.p.A.



Ciottoli in Marmo Rosso Verona



32



mm
07
15



mm
40
60



mm
15
25



mm
60
100



mm
25
40



mm
80
150



Ciottoli in Marmo Verde Alpi

35



mm
07
15



mm
40
60



mm
15
25



mm
60
100



mm
25
40



mm
80
150



Ciottoli in Marmo Giallo Siena

33



Ciottoli in Marmo Nero Ebano

34



Ciottoli in Marmo Rosso Royal

31

Pietre
Staur
S.p.A.



Granulati in Marmo Colorazioni Varie

29-35



**BIANCO
CARRARA**
MM. 8-12



VERDE ALPI
MM. 8-12



**GIALLO
MORI**
MM. 8-12



**BIANCO
THASOS**
MM. 8-12



**ROSSO
VERONA**
MM. 8-12



**BIANCO
TRANI**
MM. 8-12



**NERO
EBANO**
MM. 8-12



Lapillo Vulcanico

39

Pietre
Front
Cappi



mm
10
30



mm
30
50



Rocce Bucate Grezze



Rocce Bucate Anticate



Rocce Bucate Sabbiate

47/D



cm
10
30

47/C



cm
30
50

47/C

Arredo Giardino in Pietra Naturale



CUORI IN PIETRA



ESEMPLARI FORATI



TAVOLI IN PIETRA



PANCHINE IN PIETRA



PUNTE IN PIETRA



ESEMPLARI IN PIETRA

Fontane in Pietra



Nr. 1 - da kg. 241 a 340



Nr. 2 - da kg. 151 a 240



Nr. 3 - da kg. 241 a 340



Nr. 4 - da kg. 341 a 600



Nr. 5 - da kg. 601 a 1200



Nr. 6 - da kg. 50 a 240



Nr. 7 - da kg. 751 a 900



Nr. 8 - da kg. 901 a 1050



CASCATA

Tufo Romano e Tufo Pugliese



TUFO ROMANO

sez. cm. 37x25x11 (66 pz.)
sez. cm. 37x15x11 (115 pz.)
sez. cm. 37x11x3,7 (425 pz.)
Pedana 1000 kg.



TUFO PUGLIESE

sez. cm. 37x25x11 (67 pz.)
Pedana 1000 kg.

Pietre da Giardino Decorative

Art. 40 - METEORA



Art. 43 - LAVA NERA E ROSSA



Art. 41 - SPAGHETTI



Art. 44 - SASSI DI VETRO



Art. 42 - ROSA DEL DESERTO



ROSA LAVORATA DAL VENTO



CIOTTOLI ARCOBALENO



AGATA STONE E CALCITE





P PIETRE NATURALI NAZIONALI ED ESTERE

P. 68	PORFIDO DEL TRENINO MOSAICO	ART. 53
P. 69	PORFIDO DEL TRENINO MOSAICO GRANDE	ART. 53
P. 70	PORFIDO DEL TRENINO CUBETTI	ART. 53
P. 71	PORFIDO DEL TRENINO TRANCIATO	ART. 55
P. 72	QUARZITE BRASILIANA A MOSAICO	ART. 56
P. 73	PIETRA DI ROCCADASPIDE	ART. 57
P. 74	ARDESIA GRIGIA BEOLA	ART. 58
P. 75	ARDESIA VERDELLO E MARRONE	ART. 59
P. 76	PIETRA FOSSILE MOSAICO	ART. 60
P. 77	PIETRA DI LUSERNA MOSAICO	ART. 61
P. 78	PIETRA DI LUSERNA SQUADRATA	ART. 61
P. 79	SERIZZO FORMAZZA E ANTIGORIO	ART. 62
P. 80	ABACHINI IN ARDESIA	ART. 63
P. 81	PIETRA ALBA MOSAICO PIANO CAVA	ART. 64-66
P. 82	PIETRA ALBA MOSAICO ANTICATO	ART. 67-69
P. 83	PIETRA ALBA PIASTRELLE	ART. 70-73
P. 84	CARPARO LECCESE	ART. 78

Tipologia di Imballaggio

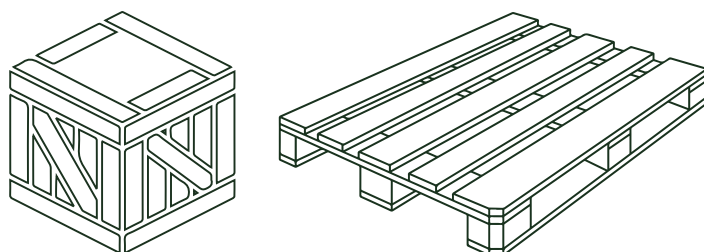

CARATTERISTICHE



PIÙ SPAZIO EDIFICABILE

Vantaggi della pietra naturale
Volumetria ridotta



FACILE INSTALLAZIONE

Spessore contenuto
Semplicità di installazione



POSA IN OPERA NATURALE

Prodotto totalmente naturale



ECONOMICO

Costi contenuti

PEZZATURE DISPONIBILI

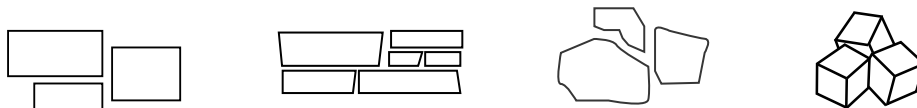

Porfido del Trentino Mosaico

53/B



53/A



53
A

spessore cm. 1-3
Pedana 1600 kg. / 30 mq.
Colorazioni indicative:
grigio, rosso

53/B



53
B

spessore cm. 3-5
Pedana 1600 kg. / 22-23 mq.
Colorazioni indicative:
grigio, rosso

Porfido del Trentino Mosaico Grande



53
C

*spessore cm. 2-5,
Diam. cm. 30/90*
Pedana 1600 kg. / 20-25 mq.
Colorazioni indicative:
grigio, rosso



53
D

*spessore cm. 3-7,
Diam. cm. 30/90*
Pedana 1600 kg. / 13-18 mq.
Colorazioni indicative: grigio, rosso

Porfido del Trentino Cubetti



testa cm. 6-8, sp. cm. 3-5

53 A Pedana 1600 kg. / 16 mq. ca.
Colorazioni indicative:
grigio, rosso

testa cm. 8-10, sp. cm. 3-5

53 B Pedana 1600 kg. / 16 mq. ca.
Colorazioni indicative:
grigio, rosso



Porfido del Trentino Tranciato



- 55 A** sez. cm. 15 a correre - sp. cm. 3-5
- 55 B** sez. cm. 20 a correre - sp. cm. 3-5
- 55 C** sez. cm. 25 a correre - sp. cm. 3-5
- 55 D** sez. cm. 30 a correre - sp. cm. 3-5

Colorazioni indicative: grigio, rosso



- 55 E** sez. cm. 15 a correre - sp. cm. 1-3
- 55 F** sez. cm. 20 a correre - sp. cm. 1-3
- 55 G** sez. cm. 25 a correre - sp. cm. 1-3
- 55 H** sez. cm. 30 a correre - sp. cm. 1-3

Quarzite Brasiliana a Mosaico

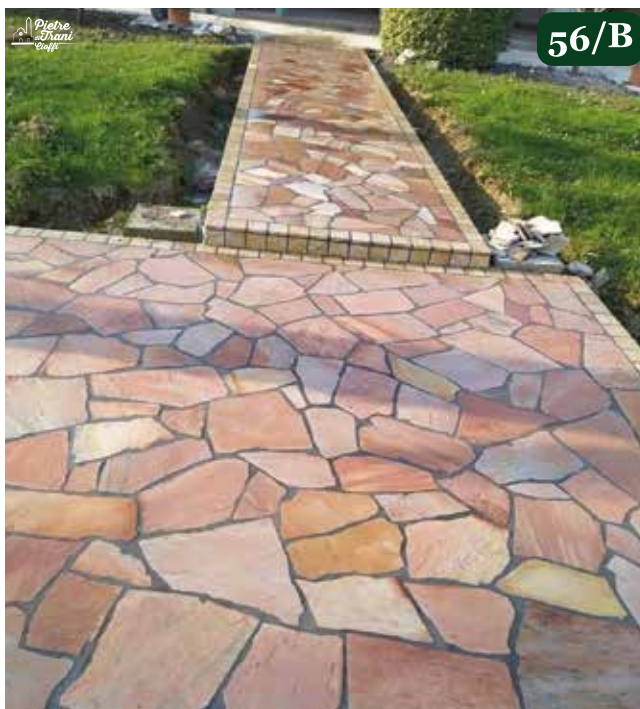

spessori mm. 8-15 / 15-25

Grandezze 10/15 pezzi a mq.

56 Pedana 1000-1800 kg. / 35-45 mq.

Colorazioni indicative: bianca, gialla o rosa



Pietra di Roccadaspide



opera incerta, sp. cm. 2-4

57 Pedana 18 mq.
Colorazioni indicative: giallo/grigio



Ardesia Grigia Beola

58/A



58/B



58
B *spessore cm. 1-3 mosaico*
Pedana 1500 kg. / 30 mq. ca.
Colorazioni indicative: grigio

58
B *spessore cm. 1-2 mosaico*
Pedana 1000 kg. / 30 mq. ca.
Colorazioni indicative: grigio

58/C



spessore cm. 2-4 piastrelle
58
C *pezzatura mista*
Pedana 1500 kg. / 20 mq. ca.
Colorazioni indicative: grigio

Ardesia Verdello e Marrone



Verdello *spess. cm. 1-3 mosaico*

59 Pedana 1500 kg. / 30 mq. ca.

Color. indicative: verde-marroncino

Marrone *spess. cm. 1-3 mosaico*

59
A Pedana 1500 kg. / 30 mq. ca.

Colorazioni indicative: marrone

Pietra Fossile Mosaico



60/B

60 spessore mm. 5-7
A Pedana 1000 kg. ca. / 60-70 mq.

60 spessore mm. 7-12
B Pedana 1000 kg. ca. / 50-60 mq.

60 spessore mm. 13-19
C Pedana 1000 kg. ca. / 30-40 mq.



60/A



60/C

Pietra di Luserna Mosaico



61 A *spessore cm. 1-2 mosaico*
Pedana 1500 kg. / 40 mq. ca.
Colorazioni indicative:
grigio-marroncino



61 B *spessore cm. 2-4 mosaico*
Pedana 1500 kg. / 25 mq. ca.
Colorazioni indicative:
grigio-marroncino

Pietra di Luserna Squadrata



61
C

spessore cm. 3-5 piastrelle
larghezza cm. 20-25-30 a/c
Pedana da 25 mq.
Colorazioni indicative:
grigio-marroncino



61
D

spessore cm. 4-6 / 6-8 / 8-10
listelli/binderi lunghezza variabile
Pedana 1800 kg.
Colorazioni indicative:
grigio-marroncino



61
C



61
D

Serizzo Formazza e Antigorio



62/B

62
A

Formazza cm. 31x15x1,5
Pedana 1500 kg. / 40 mq. ca.
Colorazioni indicative: grigio chiaro

62
B

Antigorio cm. 31x15x1,5
Pedana 1500 kg. / 40 mq. ca.
Colorazioni indicative: grigio scuro



FORMAZZA

62/A



62/B

ANTIGORIO

Abachini in Ardesia



63

cm. 57x15x0,5 - cm. 57x20x0,5 - cm. 57x25x0,5 - cm. 57x30x0,5

63 Pedana 1500 kg. / 80-100 mq. ca.

Colorazioni indicative: nero



63

Pietra Alba Mosaico Piano Cava



64 **Mosaico giallino** - spessore cm. 1-3
Pedana 1100 kg. / 22-25 mq.

65 **Mosaico rosato** - spessore cm. 1-3
Pedana 1100 kg. / 22-25 mq.

66 **Mosaico grigio** - spessore cm. 1-3
Pedana 1100 kg. / 22-25 mq.



Pietra Alba Mosaico Anticato



**67 Mosaico Anticato
Giallino**

spessore cm. 1-3
Pedana 1100 kg.
22-25 mq.



**68 Mosaico Anticato
Rosato**

spessore cm. 1-3
Pedana 1100 kg.
22-25 mq.



**69 Mosaico Anticato
Grigio**

spessore cm. 1-3
Pedana 1100 kg.
22-25 mq.



**69 B Mosaico
Anticato Viola**

spessore cm. 1-3
Pedana 1100 kg.
22-25 mq.



Pietra Alba Piastrelle



73



70

Piastrille Gialle

70 larghezze cm. 20, 25, 30 a correre - sp. cm. 2-4
Pedana 1700 kg. / 25 mq.

Piastrille Anticate Bianco-gialline

73 larghezze cm. 20, 25, 30 a correre - sp. cm. 2-4
Pedana 1700 kg. / 25 mq.



73

Carparo Leccese



78 A *cm. 50x24x2 giallo*
Pedana 30 mq.

78 B *cm. 50x18x2 giallo*
Pedana 30 mq.

78 C *cm. 46x23x2 chiaro*
Pedana 30 mq.







P

AVIMENTI E RIVESTIMENTI LAVORATI IN PIETRA E MARMO

P. 88	PALLADIANA IN PIETRA DI TRANI	ART. 79
P. 89	PALLADIANA IN TRAVERTINO	ART. 79
P. 90	PALLADIANA APULIA	ART. 82-84
P. 91	PALLADIANA MINI	ART. 85
P. 92	PIASTRELLE ANTICATE IN PIETRA E MARMO	ART. 86
P. 93	MARMETTE ANTICATE IN PIETRA DI TRANI	ART. 92
P. 94	MARMETTE SPAZZOLATE IN PIETRA DI TRANI	ART. 93
P. 95	MARMETTE BOCCIARDATE IN PIETRA DI TRANI	ART. 97
P. 96	MARMETTE BOCCIARDATE E ANTICATE IN PIETRA DI TRANI	ART. 97
P. 97	MARMETTE TRAVERTINO GOLD	ART. 93
P. 98	CHIANCHETTE ANTICATE IN PIETRA DI TRANI	ART. 94
P. 99	CHIANCHETTE ANTICATE IN TRAVERTINO	ART. 94
P. 100	COPERTINE IN PIETRA NATURALE E MARMO	ART. 87
P. 101	BATTISCOPA LUCIDO IN PIETRA E MARMO	ART. 89-91
P. 102	PIETRA DI TRANI LAVORATA A MISURA	ART. 95
P. 103	MATTONI ANTICATI IN PIETRA DI TRANI	ART. 96
P. 104	PAVIMENTI E COPRIMURO IN TRAVERTINO ANTICATO	ART. 100

Tipologia di imballaggio

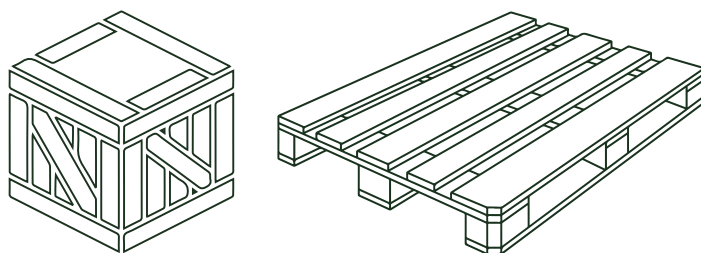

Caratteristiche



PIÙ SPAZIO EDIFICABILE

Vantaggi della pietra naturale
Volumetria ridotta



FACILE INSTALLAZIONE

Spessore contenuto
Semplicità di installazione



POSA IN OPERA NATURALE

Prodotto totalmente naturale



ECONOMICO

Costi contenuti

Pezzature Disponibili

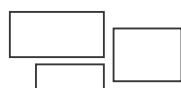

Palladiana in Pietra di Trani



79 A *Diam. 10-30 sp. cm. 1,2*
Pedana 800 kg. / 32-35 mq.
Colorazioni indicative: bianco

79 B *Diam. 10-30 sp. cm. 2*
Pedana 1800 kg. / 35-38 mq.
Colorazioni indicative: bianco

79 C *Diam. 10-30 sp. cm. 3*
Pedana 2000 kg. / 25-30 mq.
Colorazioni indicative: bianco

Palladiana in Travertino



**80
A**

Diam. 10-30 sp. cm. 1,2
Pedana 800 kg. / 32-35 mq.
Colorazioni indicative: bianco



**80
B**

Diam. 10-30 sp. cm. 2
Pedana 1800 kg. / 35-38 mq.
Colorazioni indicative: bianco



**80
C**

Diam. 10-30 sp. cm. 3
Pedana 2000 kg. / 25-30 mq.
Colorazioni indicative: bianco

Palladiana Apulia



82



82

82

Diam. cm. 7-20 - sp. cm. 1,5
Coloraz. indicativa: bianco trullaia



82
B

Diam. cm. 7-20 - sp. cm. 1,5
Coloraz. indicativa: rustica trullaia



83

Diam. cm. 7-20 - sp. cm. 1,5
Coloraz. indicativa: rosso Apulia



84

Diam. cm. 7-20 - sp. cm. 1,5
Coloraz. indicativa: giallo Apulia



Palladiana Mini



85 Diam. cm. 4-8 sp. cm. 1
Pedana 1000 kg. / 50 mq.



BOTTICINO



ROSSO VERONA



TRAVERTINO CHIARO



TRAVERTINO NOCE



VERDE GUATEMALA



GIALLO REALE



NERO EBANO



BIANCO CARRARA

Piastrelle Anticate in Pietra e Marmo



86/A



86/A

86 cm. 10x10x1 - Pedane da Mq. 25 o 50



86/A - TRAVERTINO CHIARO



86/B - ROSSO ASIAGO



86/C - VERDE ALPI



86/D - BIANCO BOTTICINO



86/E - TRAVERTINO NOCE



86/F - GIALLO REALE



86/G - BIANCO CARRARA



86/H - NERO MARQUINA

Marmette Anticate in Pietra di Trani



92
A

cm. 60x40-40x40-40x20-20x20
spess. cm. 1,5 / 30-35 mq. ca. pedana
Colorazioni indicative: bianco,
bianco avorio, beige

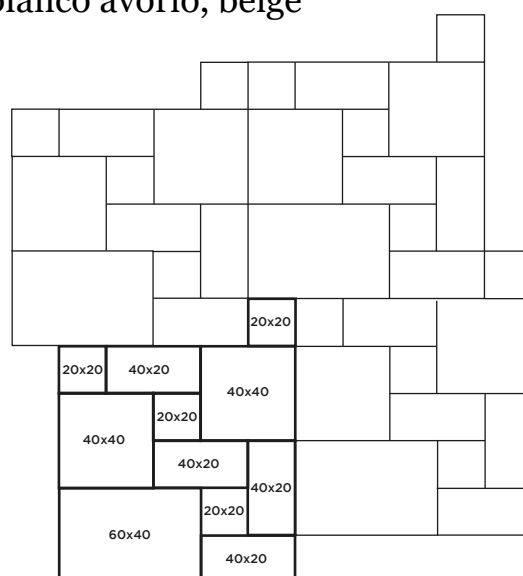

92
B

Battiscopa Anticato
cm. 10x1,5 a correre
Colorazioni indicative: bianco avorio

Marmette Spazzolate in Pietra di Trani



93

93 *cm. 60x40-40x40-40x20-20x20 - spess. cm. 1,5 / 30-35 mq. ca. pedana*
Colorazioni indicative: beige stonalizzato

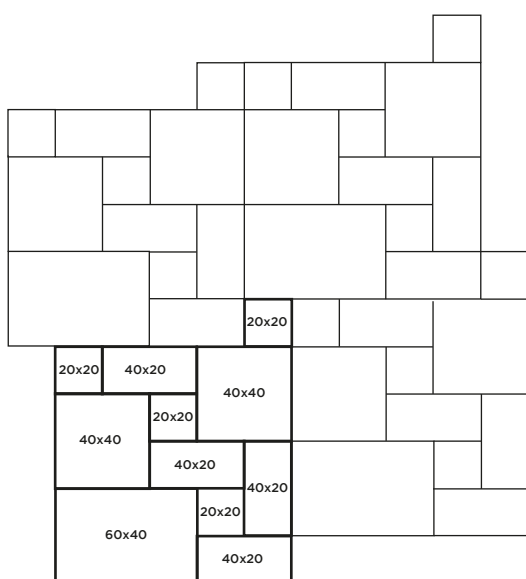

93

Marmette Bocciardate in Pietra di Trani



97/C

- 97 A** Sez. cm. 25/30 a corr., sp. cm. 1,5 - Pedana 1500 kg., 30-35 mq. ca.
- 97 B** Sez. cm. 25x50, sp. cm. 1,5 - Pedana 1600 kg., 40 mq. ca.
- 97 C** Sez. cm. 30x60, sp. cm. 1,5 - Pedana 1600 kg., 40 mq. ca.



97/B

Marmette Bocciardate e Anticate in Pietra di Trani



97
D

Sez. cm. 40 a correre,
cm. 40x60, cm. 40x40,
sp. cm. 1,5

Pedana 1500 kg.

35 mq. ca.

Colorazioni indicative:
bianco, bianco avorio



Marmette Travertino Gold

93



Pietre
Tranti
Craft

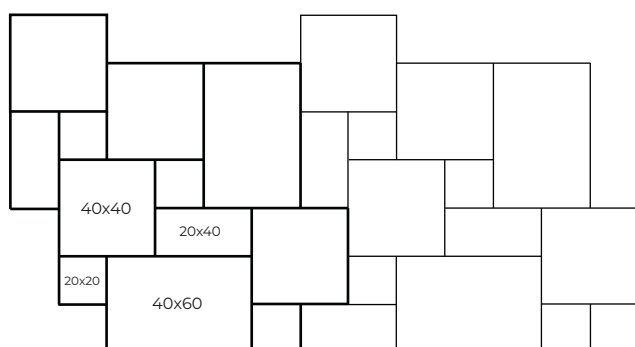

cm. 40,6x61x1,2

cm. 40,6x40,6x1,2

cm. 20x40,6x1,2

cm. 20x20x1,2

Pedana 1100 kg. / 40 mq.

Coloraz. indicative: marroncino

93



Pietre
Tranti
Craft

Chianchette Anticate in Pietra di Trani



94/A



94/A



94/B

**94
A** *spessore cm. 2 / 2,5*
Pedana 1200 kg. / 20 mq. ca.
Colorazione: bianco stonalizzato

**94
B** *spessore cm. 2,5 / 3*
Pedana 1200 kg. / 16 mq. ca.
Colorazione: bianco stonalizzato

Chianchette Anticate in Travertino



spessore cm. 1,5 / 2
94
C Pedana 1000 kg. ca. / 23 mq. ca.
Colorazioni indicative:
bianco stonalizzato

spessore cm. 2 / 2,5
94
D Pedana 1250 kg. ca. / 23 mq. ca.
Colorazioni indicative:
bianco stonalizzato

Copertine in Pietra Naturale e Marmo

*Pietra di Trani lucida
su piano e fronti
con gocciolatoi.*

87

*Larghezze da
cm. 15 a 40
spess. cm. 2, 3, 4
Pedana 1600 kg.
15-30 mq.*



*Marmo di Carrara
lucido su piano e
fronte con
gocciolatoio.*

88

*Larghezze cm. 20 e 25
spess. cm. 2
Pedana 2000-2500 kg.
40-50 mq. ca.*

*Travertino
stuccato e levigato su
piano e fronti con
gocciolatoi.*

**88
B**

*Larghezze da
cm. 15 a 60
spess. cm. 2 e 3
Pedana 2000 kg.
25-30 mq.*



Battiscopa Lucido in Pietra e Marmo

89 *Trani cm. 8x1 / 10x1*



90 *Carrara cm. 8x1 / 10x1*



91/A *Bardiglio cm. 8x1*



91/B *Perlato Royal cm. 8x1*



91/C *Perlato di Sicilia cm. 8x1*



91/D *Rosso Asiago cm. 8x1*



91/E *Travertino cm. 8x1 / 10x1*



91/G *Giallo Egitto cm. 8x1*



91/I *Verde Alpi cm. 8x1*



91/H *Nero Marquina cm. 8x1*



Pietra di Trani Lavorata a Misura



*Pietra di Trani Lavorata a Misura
per: scale, soglie, davanzali, stipiti,
architravi, bordi piscina;*
Spessori cm. 2, 3, 4, 5, 6;
Lavorazioni: lucida, levigata,
bocciardata, spazzolata.

95

BORDO PISCINA



Mattoni Anticati in Pietra di Trani

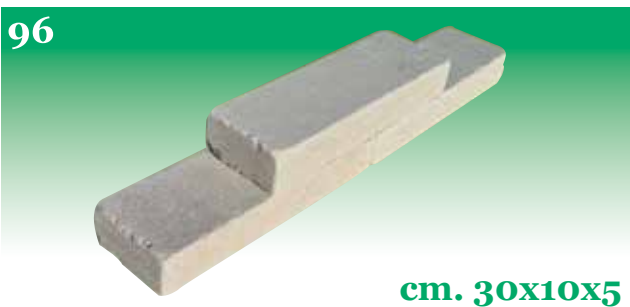

Pavimenti e Coprimuro in Travertino Anticato

100/B



100
A

cm. 15-40x4 a correre
Pedana 1800 kg. / 18 mq.

Colorazioni indicative:
paglierino chiaro



100/A

100
B

cm. 15-40x4 a correre
Pedana 1800 kg. / 18 mq.

Colorazioni indicative:
marroncino noce



100/B





P

IETRE DI TRANI PER CORDOLI E BASOLATI STRADALI

P. 108	BASOLE BOCCIARDATE SBECCATE IN PIETRA DI TRANI	ART. 101
P. 109	BASOLE PICCONATE ANTICATE IN PIETRA DI TRANI	ART. 102
P. 110	CORDOLI E ZANELLE IN PIETRA DI TRANI	ART. 103
P. 111	CORDOLI ANTICATI IN PIETRA DI TRANI	ART. 103

Tipologia di imballaggio

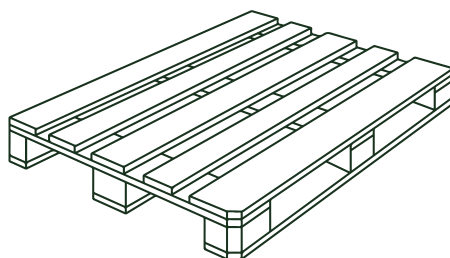

Caratteristiche



POSA IN OPERA NATURALE

Prodotto totalmente naturale



ECONOMICO

Costi contenuti

Pezzature Disponibili

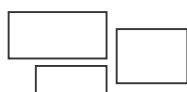

Basole Bocciardate Sbeccate in Pietra di Trani



101 *Larghezze da cm. 15 a cm. 40*
Lunghezze Variabili o a misura fissa
Spessori da cm. 3 a cm. 12
Colorazioni indicative: bianco Trani



Basole Picconate Anticate in Pietra di Trani



102

102 Larghezze da cm. 30 a cm. 40 - Lunghezze Variabili
spessori da cm. 2 a cm. 6 - Colorazioni indicative: bianco Trani



102



102

Cordoli e Zanelle in Pietra di Trani



103 sez. cm. 10x10, 10x15, 8x20, 10x20, 10x25, 15x25, 20x20, 15x30, 18x30, 20x30
Lunghezze variabili - Colorazioni indicative: bianco Trani

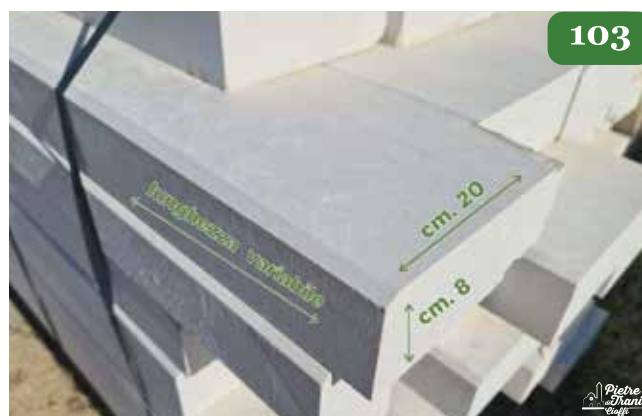

Cordoli Anticati in Pietra di Trani



104 sez. cm. 8x20, 10x20, 8x25, 10x25
Lunghezze variabili - Colorazioni indicative: bianco Trani



Accessori per Posa in Opera e Manutenzione



COLLANTI E FUGANTI PER PIETRE NATURALI
Adesivi e stucchi cementizi specifici per la posa in opera di pietre naturali e marmi



ERBA SINTETICA
prato di alta qualità, per pavimentazione aree esterne



IDROREPELLENTI PER MARMI E PIETRE NATURALI
Trattamenti per interni ed esterni



SEPARATORI PER AIUOLE
Profili per separazione e contenimento aree esterne



PAVIMENTI DRENANTI
Stabilizzatori drenanti per pavimenti pedonali e carrabili



TELI DA PACCIAMATURA
TnT in fibra di polipropilene. Aumenta capacità di permeabilità e traspirazione.

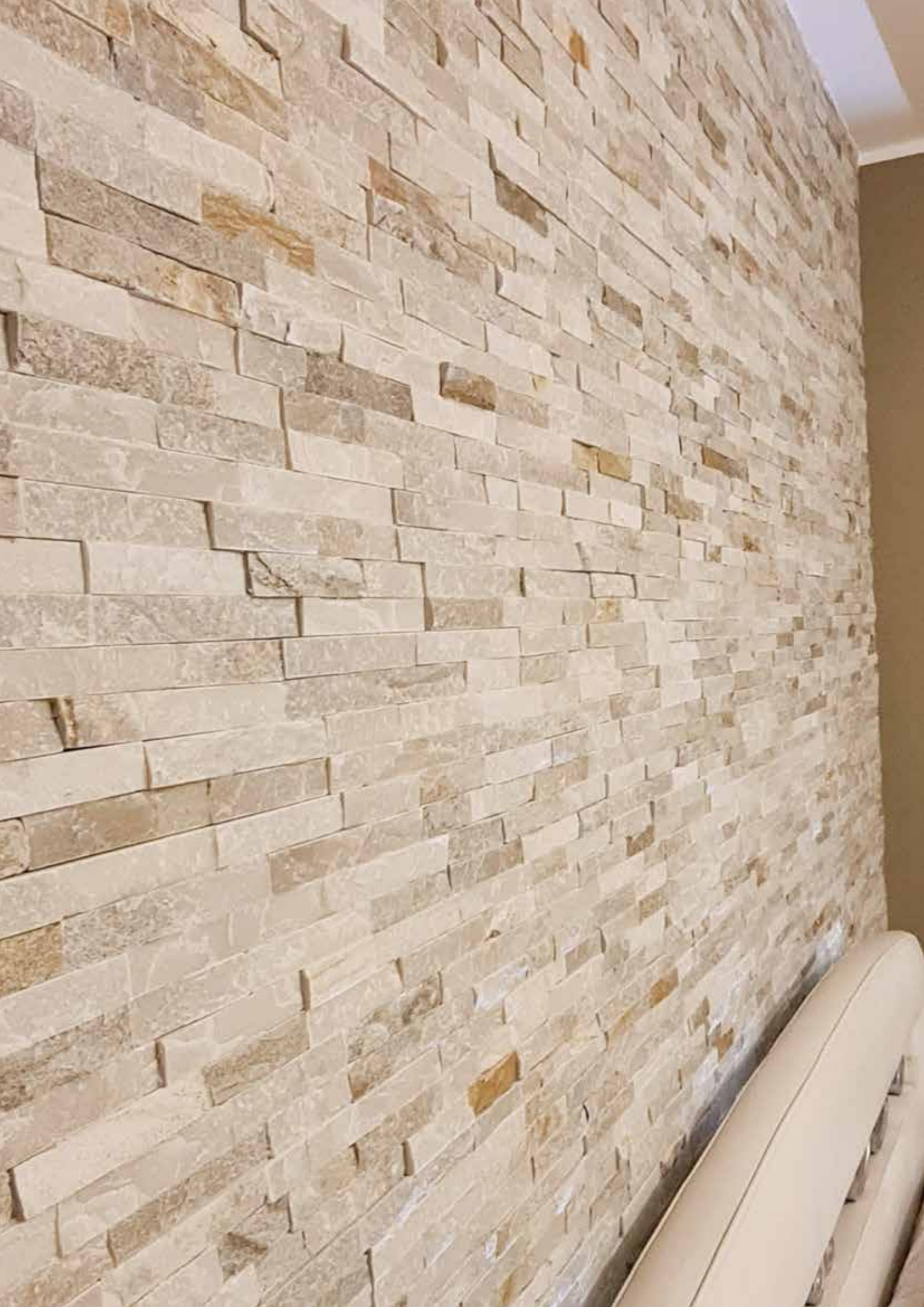

www.pietreditrani.it

